

# TRACKING OF PARALLEL BROWSING BEHAVIOUR

Martin Labaj

Prof. Mária Bielíková

Users' Behaviour

Tabbing Model

Recommendation

...

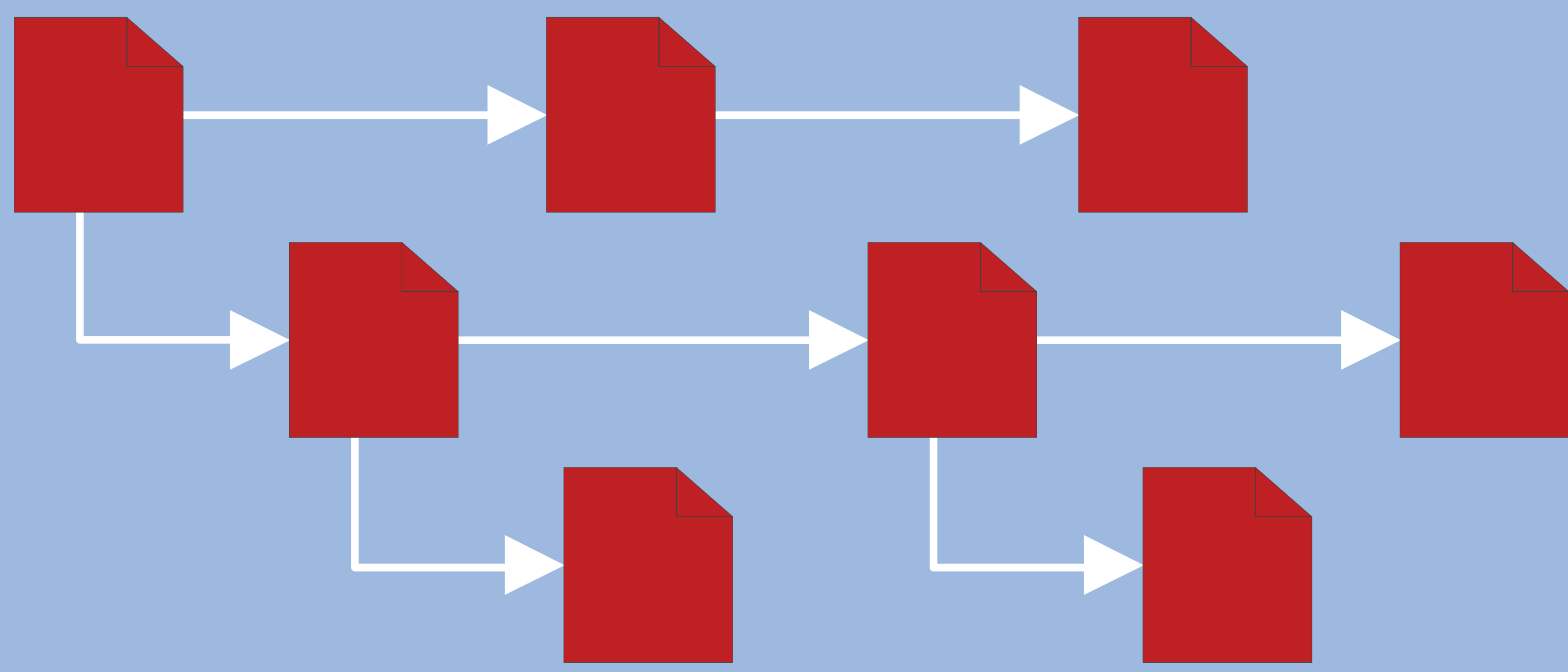

## Background

Aims

Results

- Multiple windows have been supported by web browsers for a long time
- Since 2006 all major browsers also support tabs

### Users do use tabs/windows extensively, for:

- Bookmarking (read later)
 

Interesting Blog Post	News	Urgent Work
-----------------------	------	-------------
- Task lists, reminders
 

Paper 1	Paper 2	Assignment	Funny cat videos	Social network
---------	---------	------------	------------------	----------------
- Comparison
 

Fast Laptop 3000	Cheap Laptop	Small Laptop	Gaming Laptop
------------------	--------------	--------------	---------------
- Scanning through links
 

Search Engine	Result 1	Result 2	Result 3
---------------	----------	----------	----------
- Finding more information
 

Task 1: Fibonacci	Function def.	Recursion	Compilation
-------------------	---------------	-----------	-------------

### Problems with parallel browsing modelling:

- Server logs – no tabbing information (only estimations)
- Browser extensions – unsuitable for adaptive web applications (limited user group)
- Client-side scripting – unobtrusive, but only partially researched

### Current recommendation considers only part of user behaviour (e.g. task identification)

Background

Aims

Results

- Model browsing behaviour of **all users** unobtrusively
- Detect simultaneously opened web sources and switching between them
- Recommend web sources based on parallel browsing

Background

Aims

Results

### Experimental study

- Unsupervised, users were not instructed how to browse; part of users were observed in lab
- ALEF - Adaptive Learning Framework, 216 active students, 1 month
- Browsers: Firefox (51.6%), Chrome (35.5%), Opera (9.6%), Safari (3.2%)
- 38 449 activity vectors received
- 45.8% users were doing parallel browsing**
  - 1.4% branching from within ALEF
  - 6.0% type-in/link from outside
  - 1.5% type-in on opened ALEF page
- 84.3% users were switching intensively**
  - Time spent on page: average difference of 230.2 seconds between total time and time the tab was active
  - Very long page views (longer than 24 hours) with only a few minutes long active time (bookmarking/reminders)
- Time correction for multiple users
- The model was successfully used to extend adaptive tools framework within ALEF to support tabbing**
- Further research:
  - Real-time activity vector incorporation
  - Combine the model with the model of Adaptive Proxy
  - Recommendation based on parallel switching

Tab Life

Event Mapping

Tab Switching

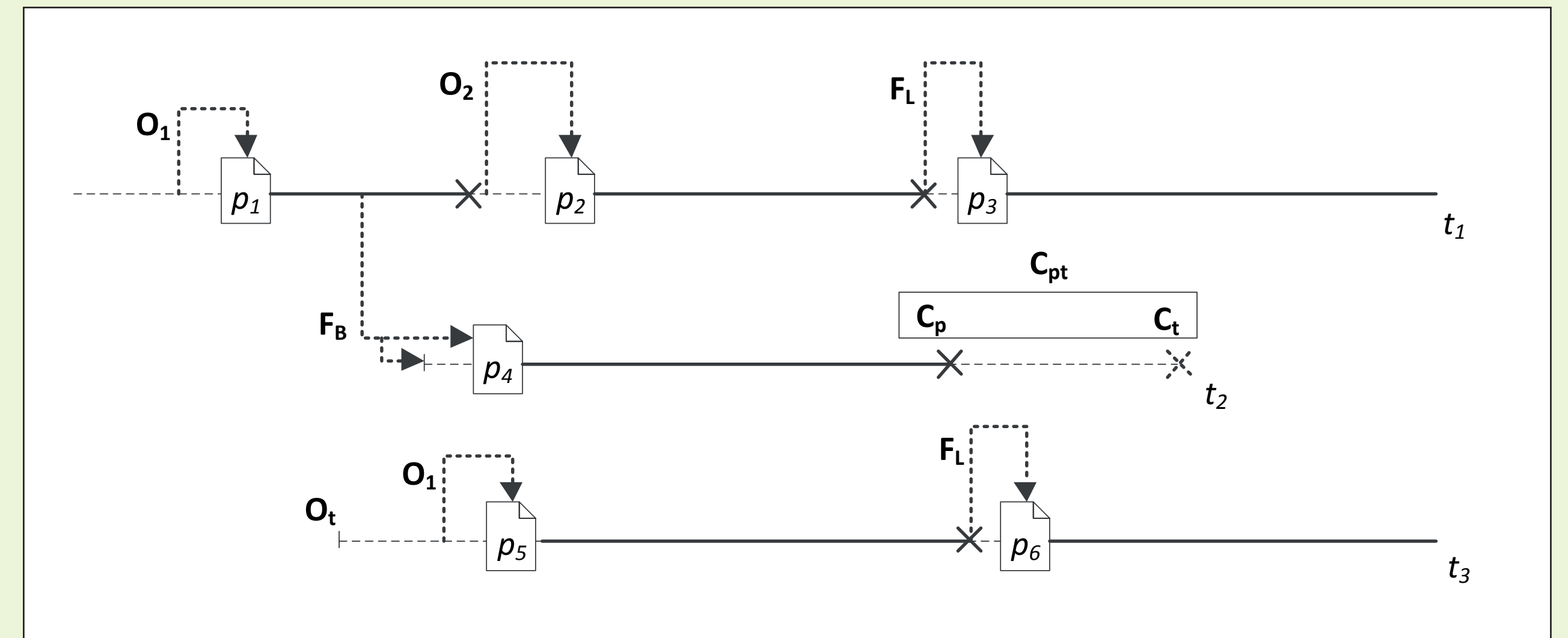

- $O_1$  – Opening a new page  $p_1$  in existing empty tab  $t_1$
- $O_2$  – Opening a new page  $p_2$  in existing tab  $t_1$  with page  $p_1$  open
- $F_L$  – Following a link to page  $p_2$  from page  $p_1$  in the same tab  $t_1$
- $F_B$  – Following a link to page  $p_2$  from page  $p_1$  in tab  $t_1$  to the new tab  $t_2$
- $C_p$  – Closing a page  $p_1$
- $O_t$  – Opening a new empty tab  $t_1$  with no page
- $C_t$  – Closing existing empty tab  $t_1$  with no page
- $C_{pt}$  – Closing existing tab  $t_1$  with page  $p_1$

Tab Life

Event Mapping

Tab Switching

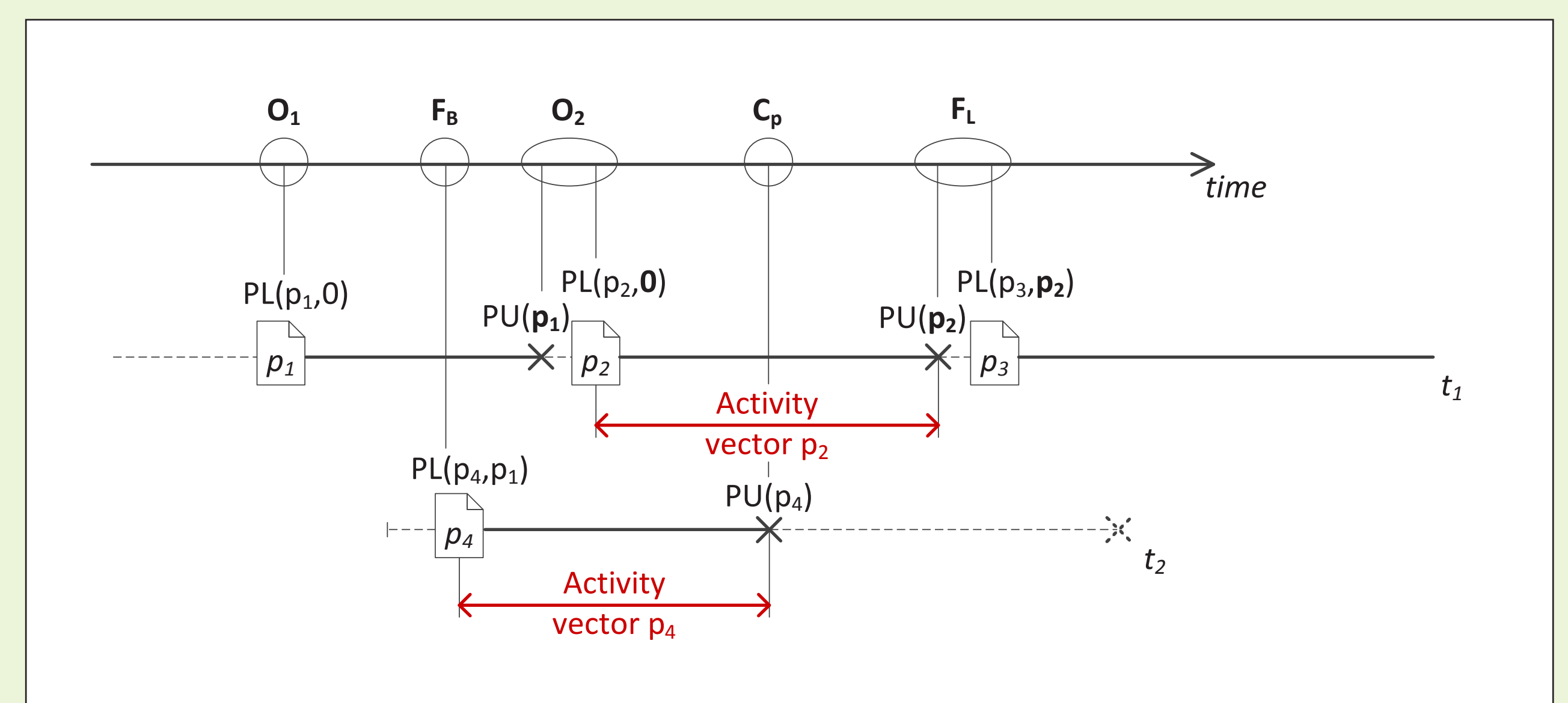

- $O_1 = PL(p_1, 0)$
  - $O_2 = PU(p_1), PL(p_2, 0)$
  - $F_L = PU(p_1), PL(p_2, p_1)$
  - $F_B = PL(p_2, p_1)$
  - $C_p = PU(p_1)$
  - $O_t = not\ def.$
  - $C_t = not\ def.$
  - $C_{pt} = C_{p1}, C_{t1}$
- $PL(p_1, p_2)$  –  $p_1$  page load, referrer  $p_2$   
 $PU(p_1)$  –  $p_1$  page unload

Tab Life

Event Mapping

Tab Switching

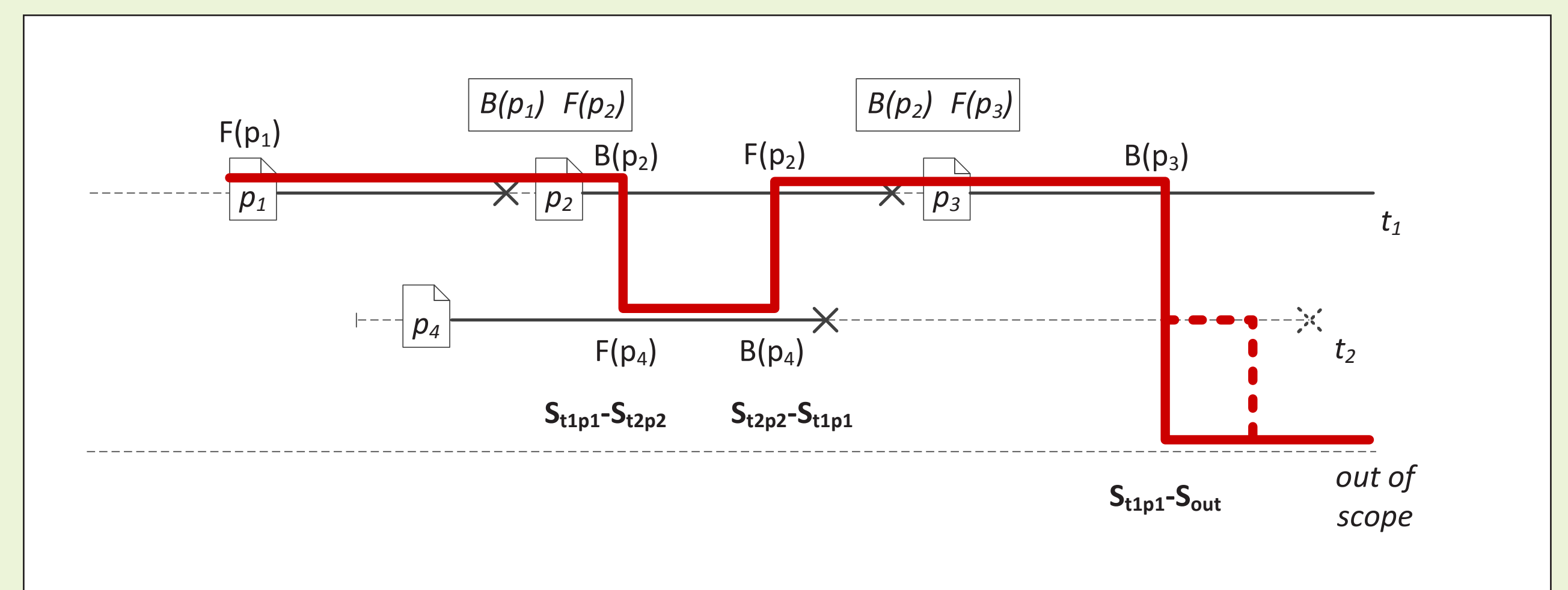

- $S_{t1p1-t2p2}$  – Switching from tab  $t_1$  with page  $p_1$  to tab  $t_2$  with page  $p_2$
  - $S_{t1p1-outX}$  – Switching from tab  $t_1$  with page  $p_1$  to out of the scope
  - $S_{out1-out2}$  – Untracked activity – switching between applications, untracked tabs, etc.
  - $S_{outX-t2p2}$  – Switching from out of the scope back to tab  $t_2$  with page  $p_2$
  - $S_{t1p1-t2p2} = B(p_1), F(p_2)$
  - $S_{t1p1-outX} = B(p_1)$
  - $S_{out1-out2} = not\ def.$
  - $S_{outX-t2p2} = F(p_2)$
- $B(p_1)$  – page  $p_1$  blur  
 $F(p_1)$  – page  $p_1$  focus